

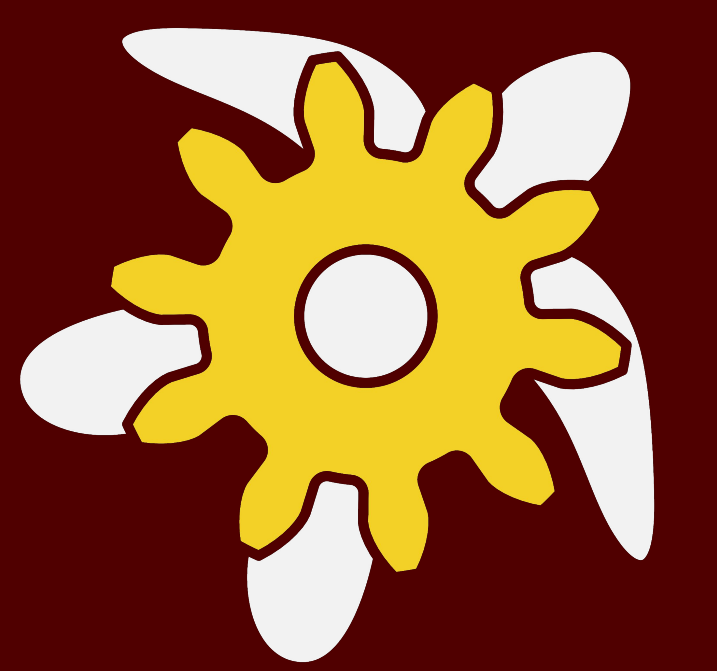

Combat Robotics (CMBT)

Project Lead: Kian Dunkin

Members: Som Datta, Elijah Deen, Aidan Donovan, Jacob Lester, Wyatt Moritz, William Shan, Spencer Shushan, Addison Pardini, Sam Harsch, Jonathan Pena, Raquel Bauhs, Andrew Sun



Combat Robotics

The Combat Robotics Team (CMBT) designs, manufactures and competes using combat robots in the 3 & 1 lb weight classes. In combat robotics competitions, robots use kinetic weapons such as flywheels and saws to disable the opposing robot. Essentially, it's a 3-minute fight to the death! If no robot is KO'd within the 3 minute match, a judging panel determines the winner.

All competitions strictly prohibit projectiles, explosives, or entanglement devices. This preserves the spirit of the competition!

Team Breakdown

4 subteams:

- two 3lb teams
- two 1lb teams

Each team designs a robot from scratch for their respective weight class. They operate independently, but are advised by previous builders. The goal is to build and compete a combat robot within two semesters!



Figure 1. A live BattleBots Competition [BattleBots]

Snapper! (3 lb)

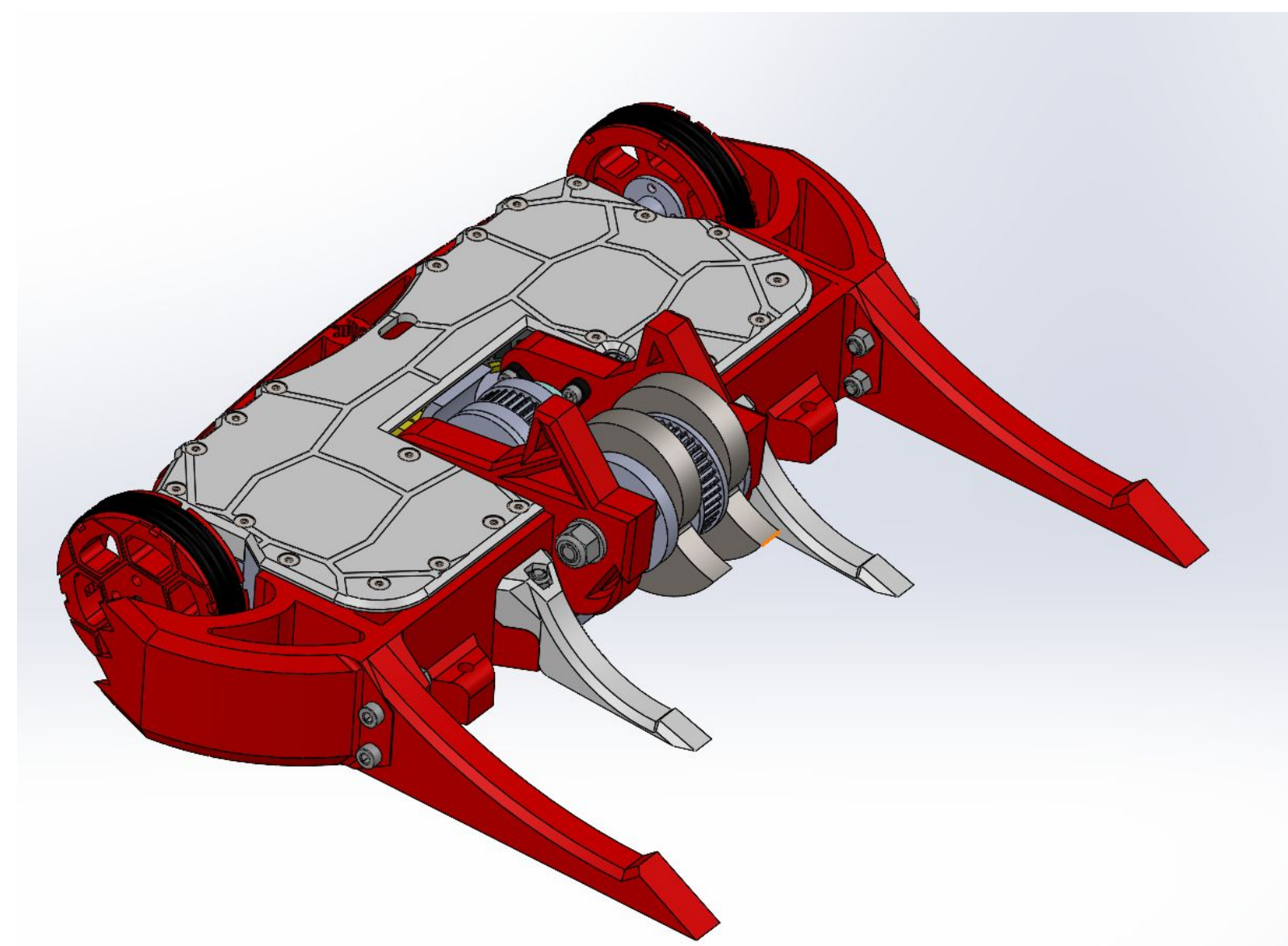

Figure 2. SolidWorks Rendering of Snapper.

Snapper is CMBT's first competing combat robot! It utilizes a dual spinning disc with a 2.5" effective diameter and 3/8" bite to deliver kinetic blows to its opponents. It has a direct-driven 2-wheel-drive system and it is surrounded by shock-absorbent TPU armor.

Snapper's downfall

On December 13th 2025, Snapper! competed at the TRC Texas Cup against the best combat robots in the world. It was promptly disemboweled, earning our team the "most destroyed" award. This exposed many areas for improvement:

- two-wheel-drive not maneuverable enough
- 3D-printed chassis not strong enough
- weapon diameter not large enough for chassis geometry



Figure 3. Snapper getting launched

Raven (3 lb)

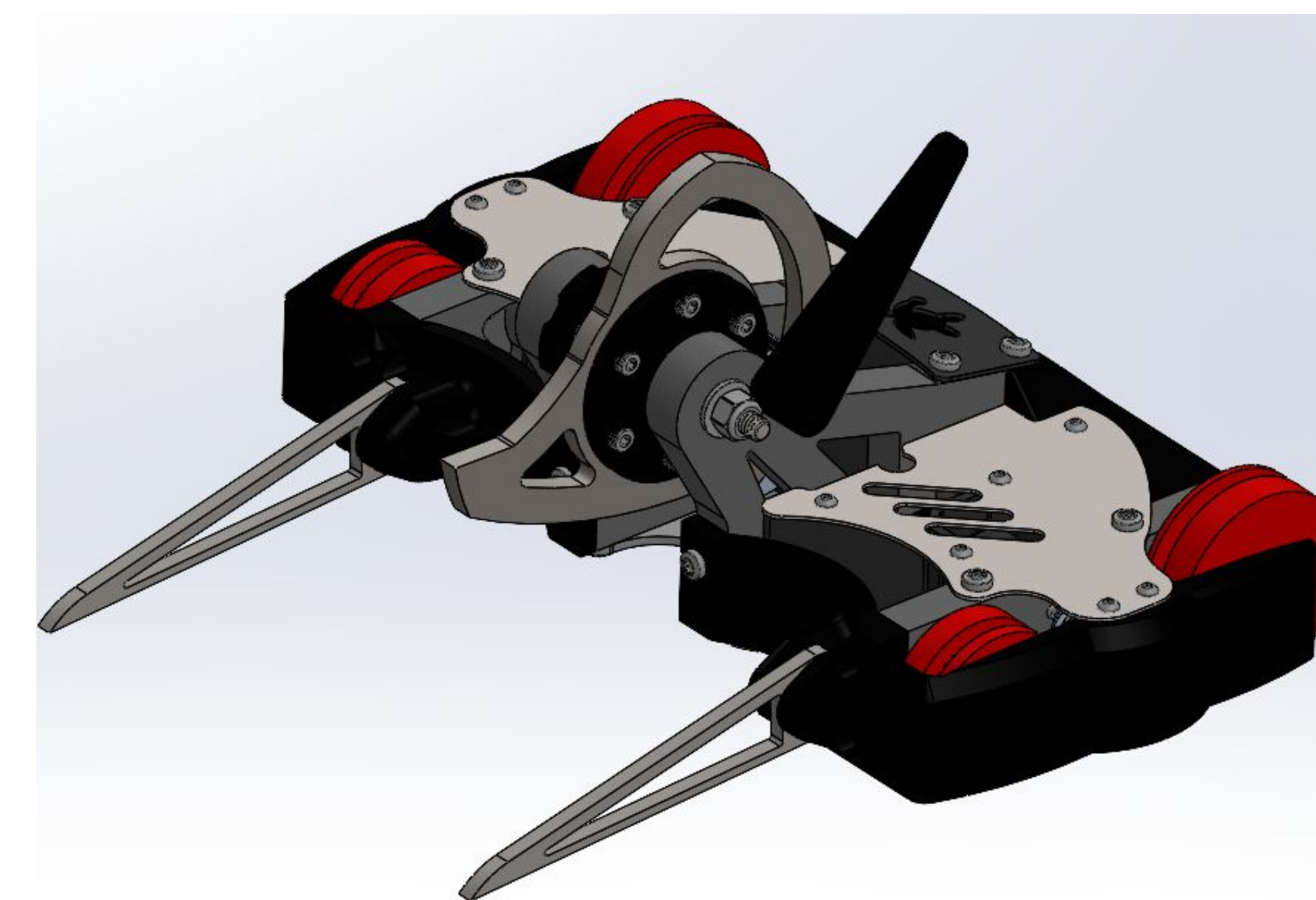

Figure 4. SolidWorks Rendering of Raven

Raven is CMBT's newest competitive 3 lb combat robot, here's what we upgraded from Snapper:

- 4-wheel-drive for increased maneuverability
- Stronger chassis custom machined from Carbon fiber, HDPE and titanium
- 5.5" effective weapon diameter

Raven's First Competition (4/11/26)



Figure 5. Raven fighting a horizontal spinner

Raven's drive system, weapon system, and durability were proven to be a significant improvement over snapper's at it's debut competition. Despite this, the competition still exposed weaknesses that need to be addressed:

- weapon system durability must be upgraded
- weight in the weapon must be reduced to allow for further reinforced armor.
- chassis geometry must be optimized for inverted driving and self-righting.

Bots In Development

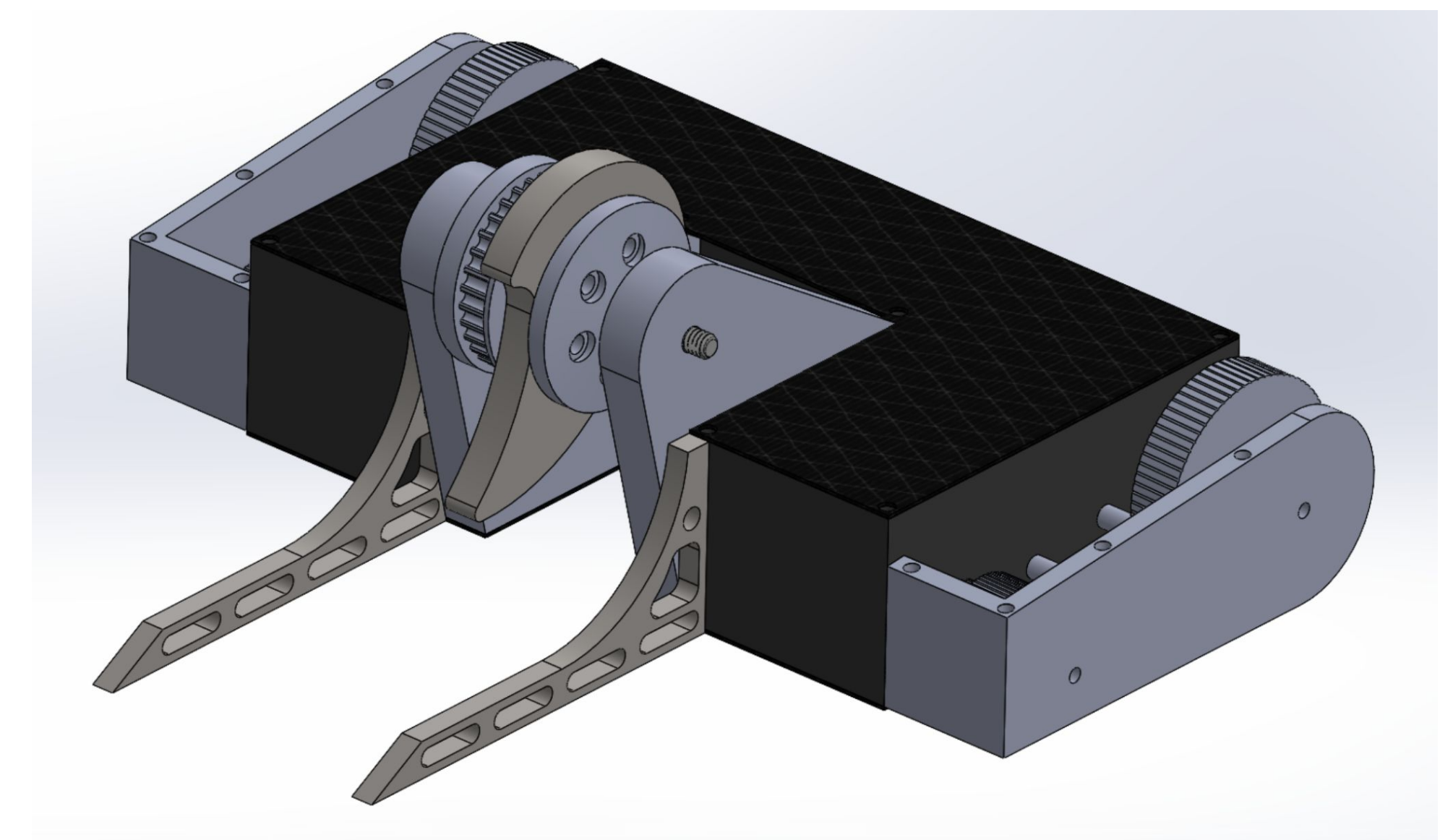

Figure 6. upcoming 3lb robot design with a vertically spinning disc weapon

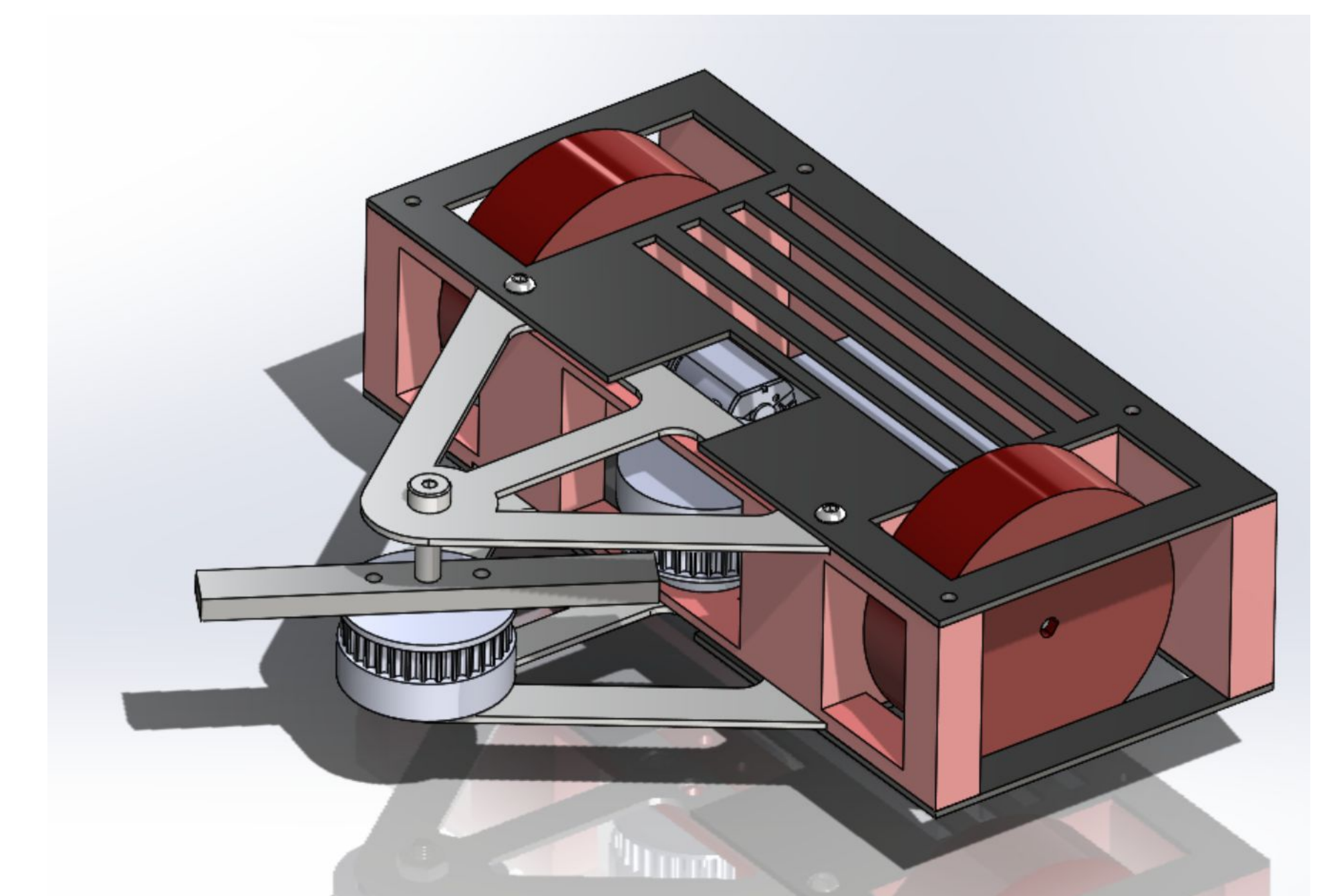

Figure 7. upcoming 1lb robot with horizontal spinning weapon

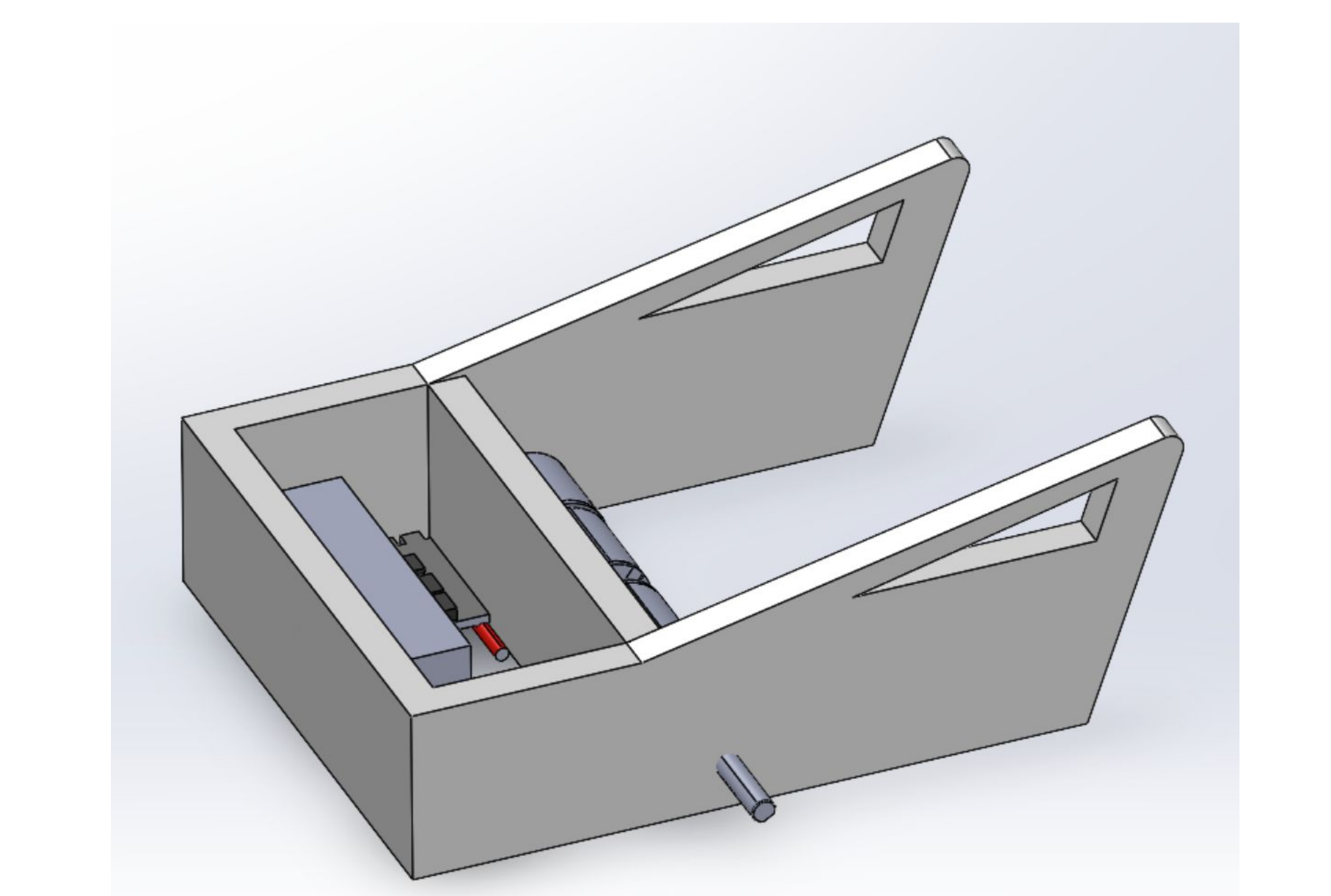

Figure 8. upcoming 1lb robot design (still in early stages)